

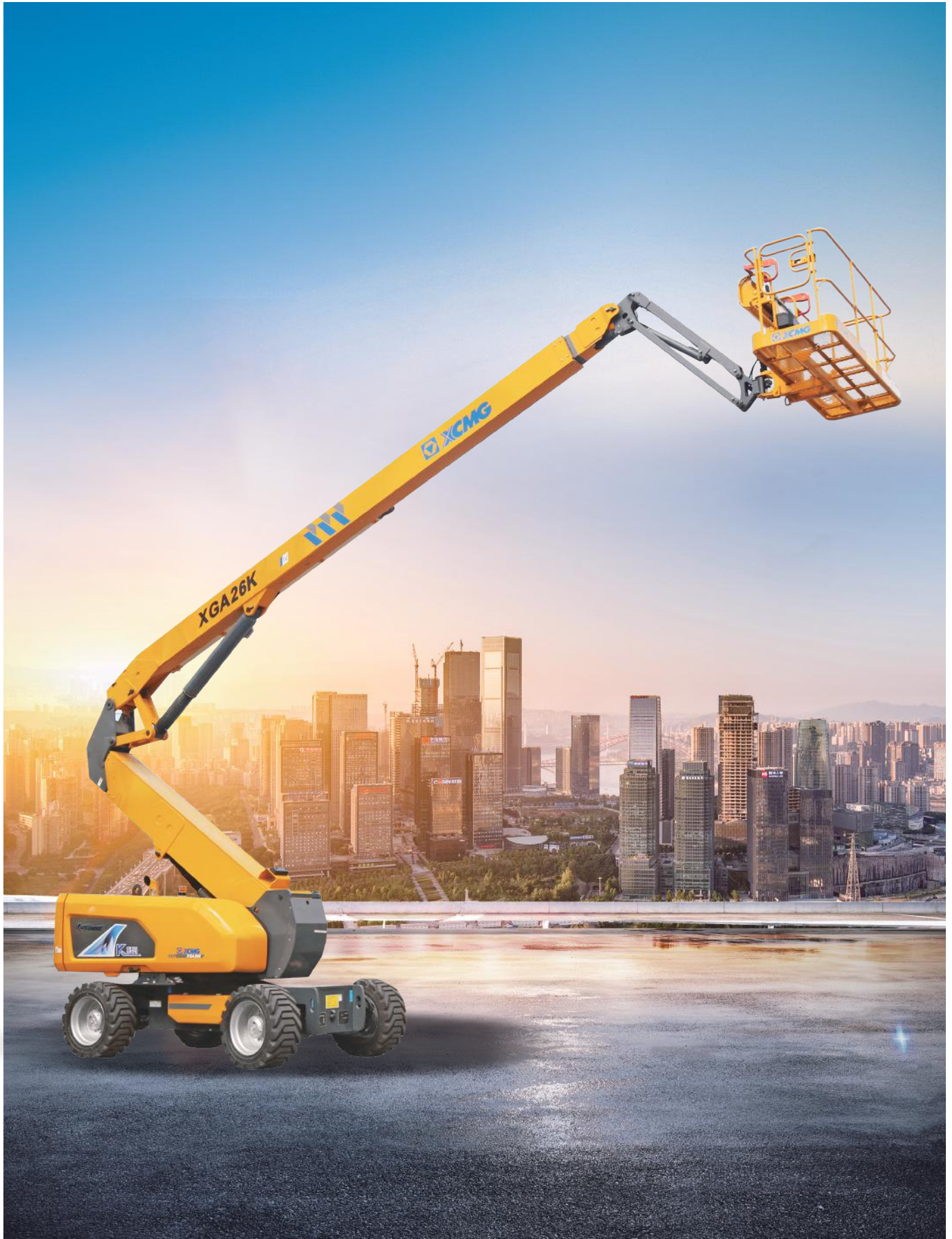

**SOLID**  
TO SUCCEED

ARTICULATED BOOM LIFT

**XGA26K**



The print does not belong to the contract, nor a part of the vehicle purchase contract. We reserve the right to revise the product model, parameters, configuration based on the continuous improvement requirements of the product, without prior notice. Pictures are for reference only, and the specific product shall depend on the real product.

# XGA26K

## Articulated boom lift

### FEATURES

#### MEASUREMENTS

26.6m working height  
 Up to 150/256kg lift capacity

#### PRODUCTIVITY

2.4m x 0.9m working platform  
 3 entry type platform with side swing doors  
 160° platform rotation  
 4-wheel drive  
 Axle balance system  
 Platform and chassis emergency stop  
 Emergency power unit  
 Axle balance pressure detection system  
 4-wheel braking system

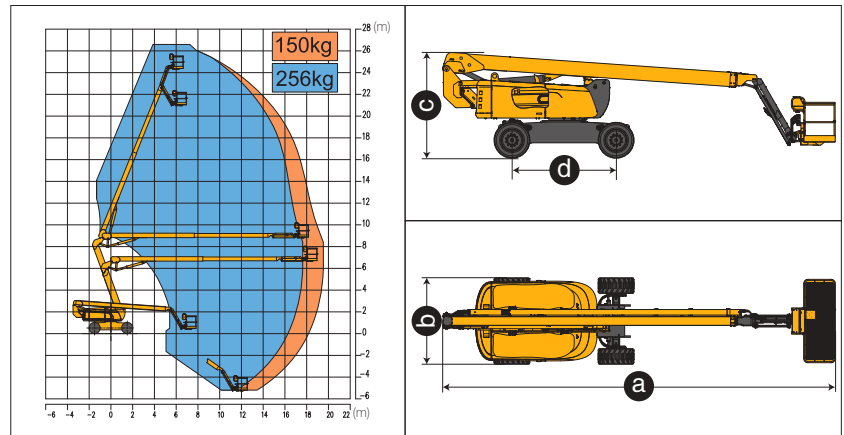

#### POWER

12V DC emergency power  
 Cold start components  
 Engine air pre-filter kit  
 Engine condition monitoring and start protection device  
 Kubota Euro stage V emission

### OPTIONS

Tool tray  
 Work light assembly  
 Foam-filled rough terrain tires

Item	Unit	XGA26K
Working height	m	26.6
Platform height	m	24.6
Working radius	m	19.5
Lift capacity	kg	150/256
Occupant capacity	-	2
1st Boom luffing range	°	-1~+70
2nd Boom luffing range	°	-35~+68
Fly jib luffing range	°	-65~+70
Turntable rotation	°	360
Platform rotation	°	160
Drive speed (retracted/extended)	km/h	5/0.6
Turning radius (inside/outside)	m	2.2/4.4
Tailswing	mm	1330
Ground clearance	mm	380
Gradeability	%	45
Tires	-	18-625
Power source	-	Kubota V2607
Rated power	kW/(r/min)	48/(2400)
Fuel tank	L	180
Hydraulic tank	L	150
Weight	kg	18100
Platform size	mm	2400x900
a Length (transportation)	mm	11760/9900
b Width	mm	2490
c Height	mm	2950
d Wheelbase	mm	3000